

Stairs SP Series

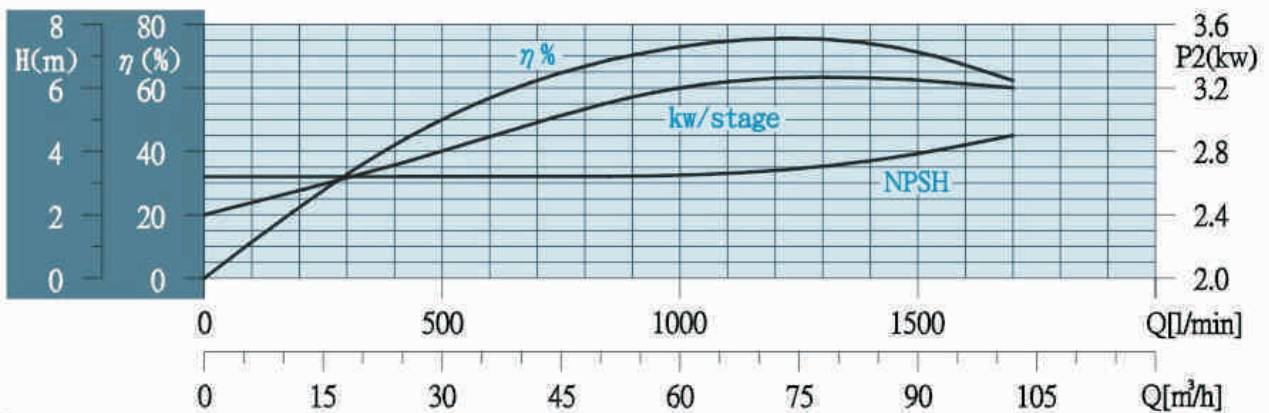

SP 8"

SP400 Performance Curves

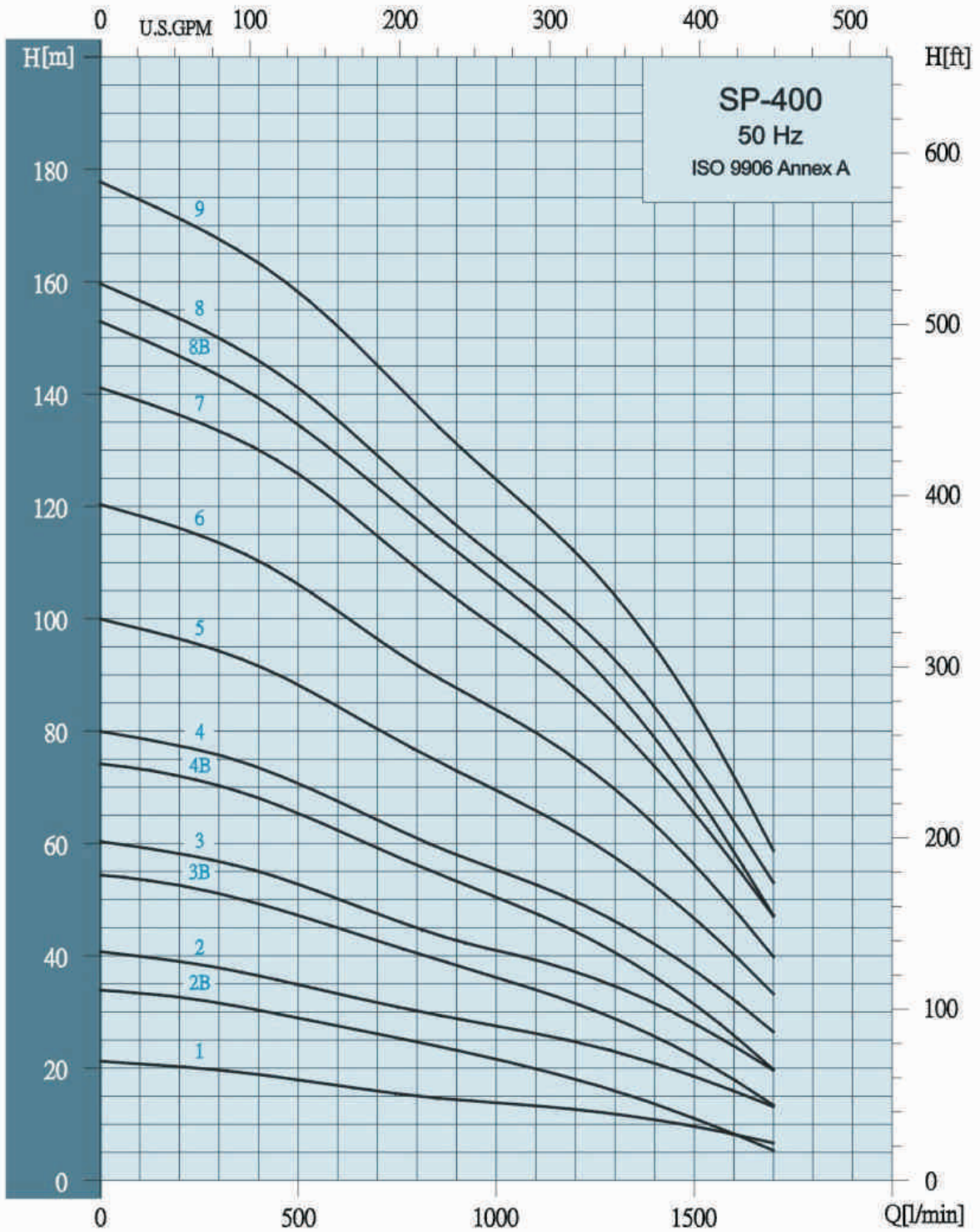

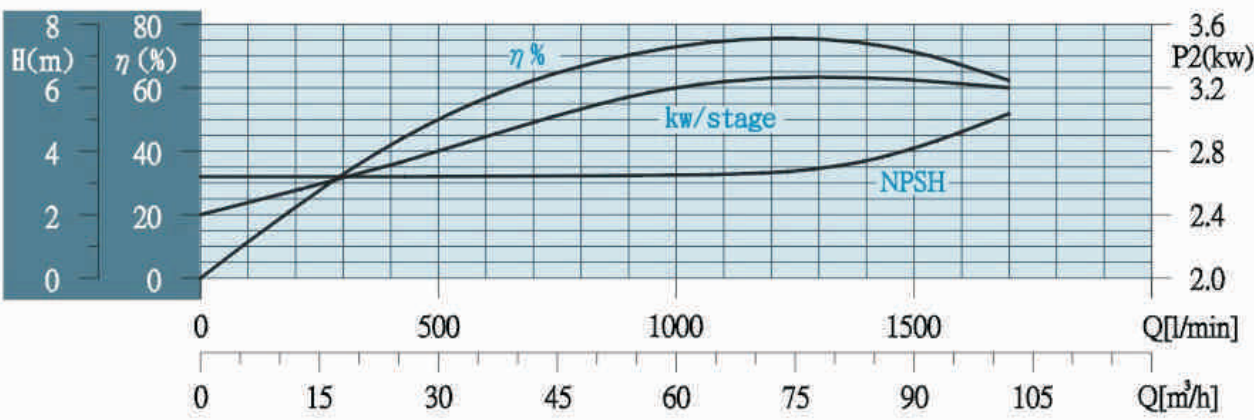
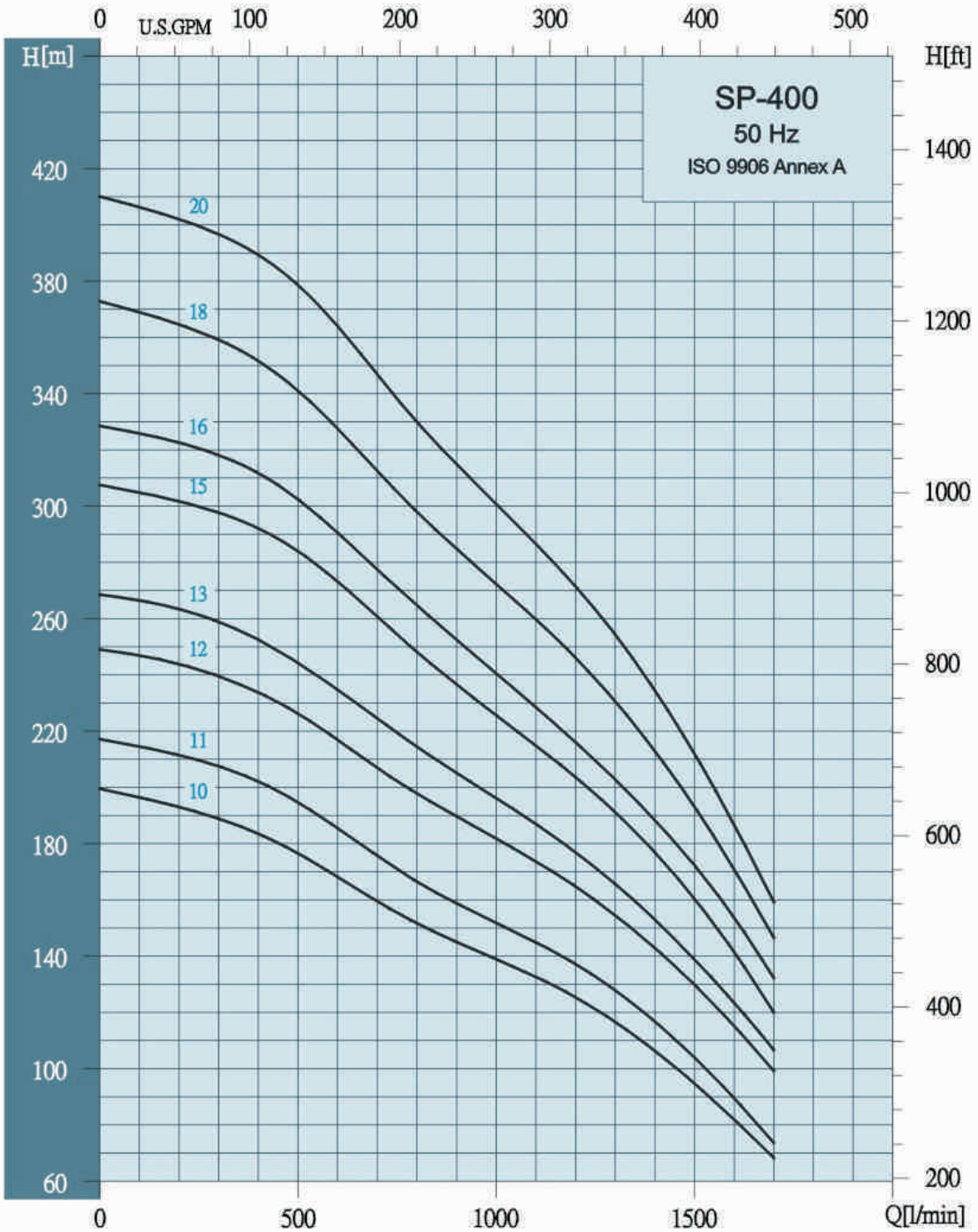

Selection Chart

Pump Type	Motor		Max.current		m ³ /h l/min	Q capacity 2900 rpm											
	P2		Amp			12	18	24	30	36	42	48	54	66	78	90	102
	KW	HP	220V	380V		200	300	400	500	600	700	800	900	1100	1300	1500	1700
SP 400-1	5.5	7.5	21.9	12.7	HEAD IN METERS	20	19.5	19	18	17	16	15	14	13	12	9	7
SP 400-2-B	5.5	7.5	21.9	12.7		33	32	30	28	27	26	25	23	20	16	11	6
SP 400-2	7.5	10	28.5	16.5		38	37	36	35	33	32	30	28	26	23	18	13
SP 400-3-B	9.3	12.5	36	20.9		53	51	49	47	45	43	40	38	34	28	22	13
SP 400-3	11	15	41.8	24.2		58	57	55	53	50	47	45	43	39	35	28	20
SP 400-4-B	13	17.5	50	29		72	70	68	65	62	59	56	53	47	40	31	20
SP 400-4	15	20	55	32		77	76	74	71	67	64	61	58	53	46	37	27
SP 400-5	18.5	25	69	40		96	94	92	88	84	80	76	73	66	57	46	33
SP 400-6	22	30	81	47		116	113	110	106	101	96	92	88	80	70	56	40
SP 400-7	26	35	96	56		136	133	130	126	120	115	109	104	93	81	65	47
SP 400-8-B	26	35	96	56		147	143	139	134	129	123	117	112	101	87	69	47
SP 400-8	30	40	111	64		153	150	146	141	135	129	123	117	105	93	75	53
SP 400-9	30	40	111	64		171	167	163	158	152	145	138	131	118	104	84	58
SP 400-10	37	50	138	80		193	188	183	177	168	160	152	145	132	117	94	68
SP 400-11	37	50	138	80		211	207	202	195	186	176	167	159	145	128	104	74
SP 400-12	45	60	154	89		244	240	234	227	217	207	198	190	173	154	130	99
SP 400-13	55	75	192	111		263	259	252	244	235	224	214	205	187	166	139	107
SP 400-15	55	75	192	111		302	298	292	284	273	260	248	237	215	191	160	120
SP 400-16	63	85	240	139		322	318	312	302	290	278	265	252	228	202	172	132
SP 400-18	63	85	240	139		365	359	352	341	328	312	298	285	260	230	193	147
SP 400-20	75	100	256	148	402	397	389	379	364	347	330	315	287	254	212	159	

*Higher pressure, longer stages pumps up to 22 stages are available on request.

Dimensions And Weights

Pump Type	Dimensions(mm)						Net Weight(Kg)
	B 5" Connection (RP,NPT)			B 5" Flange			
	A	C*	C**	A	C*	C**	Pump
SP 400-1	618	178	186	618	200	200	25.1
SP 400-2-B	746	178	186	746	200	200	28.7
SP 400-2	746	178	186	746	200	200	28.7
SP 400-3-B	874	178	186	874	200	200	32.3
SP 400-3	874	178	186	874	200	200	32.3
SP 400-4-B	1003	178	186	1003	200	200	35.9
SP 400-4	1003	178	186	1003	200	200	35.9
SP 400-5	1131	178	186	1131	200	200	35.9
SP 400-6	1259	178	186	1259	200	200	43.0
SP 400-7	1387	178	186	1387	200	200	46.6
SP 400-8-B	1515	178	186	1515	200	200	50.2
SP 400-8	1515	178	186	1515	200	200	50.2
SP 400-9	1644	178	186	1644	200	200	53.8
SP 400-10	1772	178	186	1772	200	200	57.4
SP 400-11	1900	178	186	1900	200	200	61.0
SP 400-12	2039	200	204	2039	209	209	66.0
SP 400-13	2168	200	204	2168	209	209	69.6
SP 400-15	2424	200	204				76.8
SP 400-16	2552	200	204				80.4
SP 400-18	2809	200	204				87.6
SP 400-20	3065	200	204				94.8

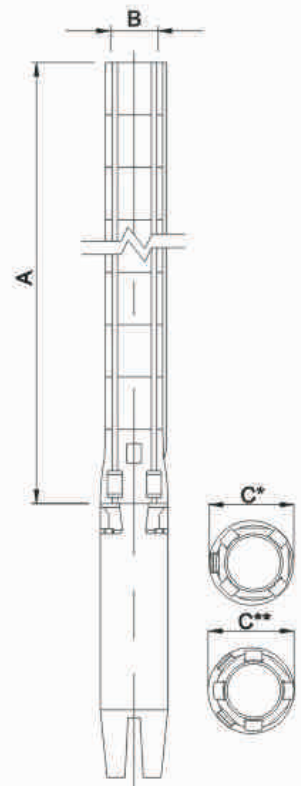

C*: Maximum diameter of pump with one motor cable

C**: Maximum diameter of pump with two motor cable