



# PRESSCONTROL





## **PRESSCONTROL**

**PRESSCONTROL** is a device with a new concept that guarantees optimal control of pumps for home use. Deriving from a hydraulic and electronic logics project, it is capable of simultaneously detecting both the pressure and the flow, as well as automatically managing the pump operation.

It replaces the traditional expansion tank system, protecting the pump in the case of a water shortage.

Far more compact than traditional systems, it is totally reliable, resistant, and easy to install.



## Applications and Performance

## PRESSCONTROL

- Replaces the traditional expansion tank system.
- Starts and stops the pump in accordance with the opening and closing of the taps.
- Maintains constant pressure during delivery.
- Stops the pump in the case of water shortage, protecting it from dry running.
- Attenuates the effects of water hammering.
- Maintenance-free.





## Technical Features - Electrical Parts

**PRESSCONTROL**

|                                |               |
|--------------------------------|---------------|
| Monophase power supply voltage | 230V          |
| Acceptable voltage variations  | ± 10%         |
| Frequency                      | 50-60 Hz      |
| Maximum current                | 16 (8) A      |
| Maximum power                  | 1,5 kW (2 HP) |

The electronic board accepts minimum voltage variations of 207V and maximum variations of 253V with a frequency of 50/60 Hz.

It supports a rated current for resistive loads of up to 16 A, and a rated current for inductive loads of up to 8 A.

It is capable of controlling a monophase motor with a maximum power of 1.5 kW equivalent to 2HP.





## Electronic Board

- Varistor on the line protecting against voltage peaks.
- Varistor protecting against relay contacts.
- Relay with two complete 16A contacts in parallel for piloting the monophasic motors of up to 2HP.

The boards are subjected to burn-in treatment at 50 °C for 24 hours with on/off cycles guaranteeing perfect operation in limit conditions and each are individually tested.

**PRESSCONTROL**





## Technical Features - Electrical Board Box

**PRESSCONTROL**

### **Type 1C device**

A device that works in such a way as to interrupt the electrical circuit by means of a microswitch (the circuit is opened and closed by relays).

### **Protection degree IP65**

The number 6 indicates that the electronic board is completely dust-proof. The number 5 indicates that the electronic board is protected against jets of water arriving from any direction.



### **Maximum operating temperature 65 °C**

The device is built to work in an environment in which the temperature may reach 65 °C .



## Technical Features - Hydraulic Parts

**PRESSCONTROL**

### Maximum operating pressure 10 bar (1 MPa)

Standards establish that that device must:

- Resist for one minute without any visible loss of pressure equal to twice the maximum operating pressure (20 bar).
- Resist for one minute at a pressure equal to four times the maximum operating pressure (40 bar).
- It must also be demonstrated that the device can release a pressure equal to four times the maximum operating pressure (40bar) without dropping in such a way as to be hazardous for humans.





## Testing of Hydraulic Parts

## PRESSCONTROL

The hydraulic parts of each device are tested individually by means of electronic instruments that detect and memorise the pressure and flow values.

In particular, the tests control the following by means of a PLC:

- Watertight sealing at maximum pressure and therefore the absence of leaks.
- The intervention value of the pressure gauge (restarting).
- The value of the minimum flow below which the flow switch stops the pump.
- Intervention of the stopping function in the event of dry running of the pump.
- Starting and stopping of the pump.



Examples of the components are tested individually to ascertain compliance with the requested technical features.

A percentage of the assembled hydraulic parts are tested on test rigs in limit conditions of continuous operation to ascertain their duration over time.



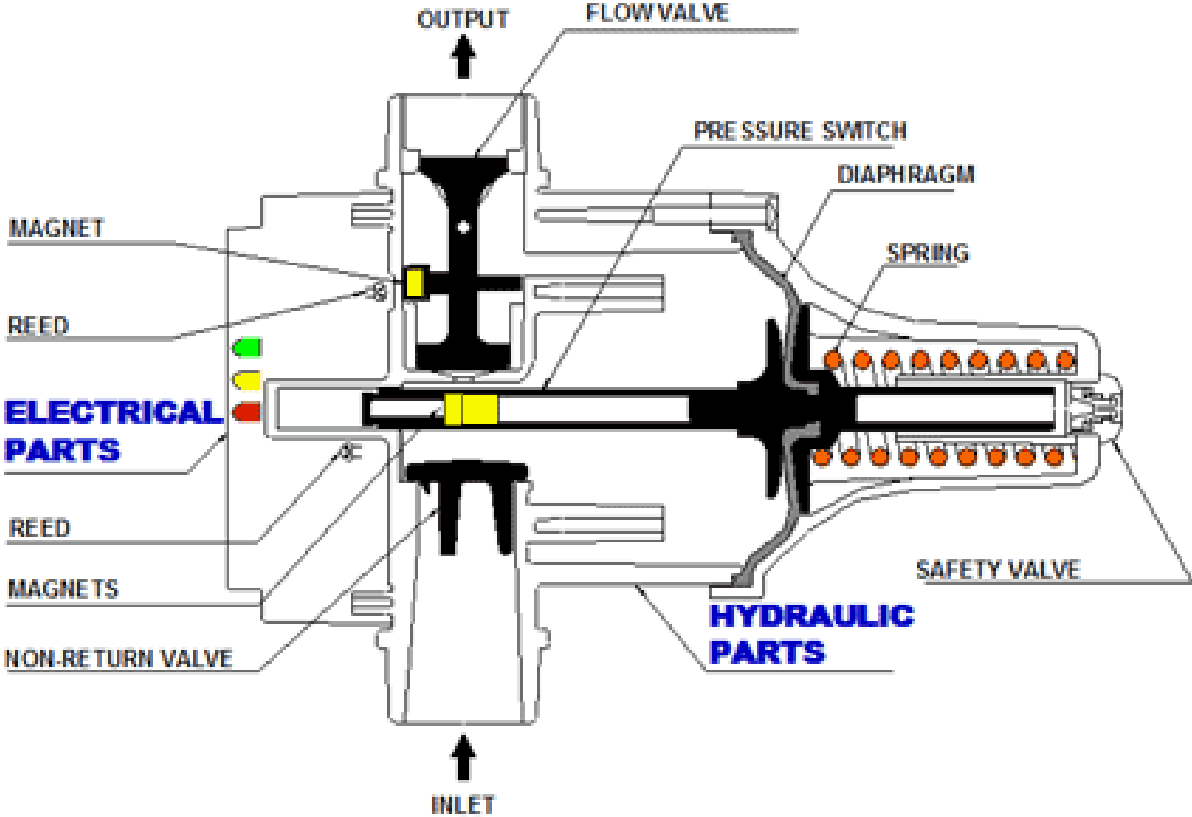



## Materials

## PRESSCONTROL

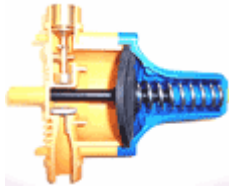

Body, non-return valve, rear part and safety valve are moulded in 30% fibreglass reinforced polyamide 6 (PA6GF30).

*This allows for obtaining a high resistance to wear and pressure.*

The diaphragm is moulded in EPDM ( Ethylene Propylene Diene Monomer).  
*This guarantees exceptional reliability and durability.*

The flow valve, pressure gauge rod and the diffuser are all in brass (OT58).  
*The dimensional stability of the metal guarantees the operation of the components.*

The spring is made in UNI 3823 steel wire.  
*The stabilisation process guarantees the operation of the pressure switch, essential for the pump start-up precision and the plant pressure adjustment. The dimensions and structure of the same allow for considerably reducing the effects of water hammering.*



The box containing the electrical part is moulded in shockproof self-extinguishing polystyrene (PSau).

The use of prime materials and top-of-the-range components allows for achieving high levels of dimensional stability, resistance to wear and bursting, and duration over time as opposed to other products made with poorer quality materials and components often not admitted by the EEC standards.



## Installation

The device can be mounted either directly onto the pump or between the pump and the first tap.

If the input pressure of the device exceeds 10 bar (1 MPa), install a pressure reducer between the pump and the device itself.

No tap must be mounted between the pump and the device.

It is essential to mount the device with the flow arrows pointing upwards (fig. A).

## PRESSCONTROL

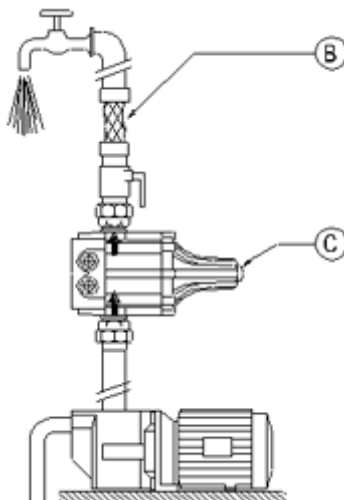
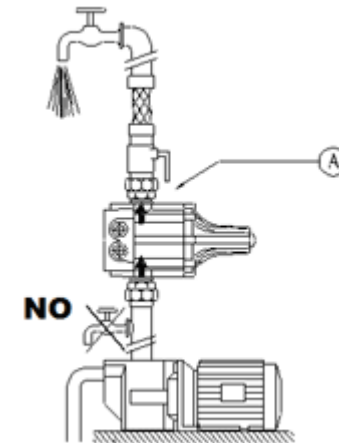

It is recommended to connect the output of the device to the plant by means of a ball valve and flexible tube (fig. B).

Before starting the device check that the pump is correctly primed.



## Select the Calibration

## PRESSCONTROL

The PRESSCONTROL comes in three different versions which only vary in their restart pressure calibrations:

- 1,2 bar (0,12 MPa)
- 1,5 bar (0,15 MPa)
- 2,2 bar (0,22 MPa)

The restart pressure value is factory-calibrated and cannot be modified.

### **ATTENTION**

Before installing check that the technical features of the device, pump and system are all compatible.

In particular, the pressure generated by the pump must normally be at least 1 bar (0.1 MPa) higher than the restart pressure of the device otherwise the pump will fail to work.



## 1,2 bar (0,12 MPa) Restart Pressure Calibration

The pressure of the pump must be a minimum of 2.5 bar (0.25 MPa), and a maximum of 10 bar (0.1 MPa).

The water column between the device and the highest tap must not exceed 10 metres.

## PRESSCONTROL

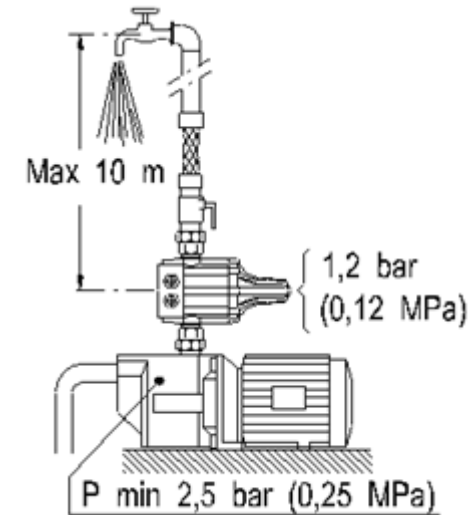



## 1,5 bar (0,15 MPa) Restart Pressure Calibration

The pressure of the pump must be a minimum of 3 bar (0.30 MPa), and a maximum of 10 bar (0.1 MPa).

The water column between the device and the highest tap must not exceed 15 metres.

## PRESSCONTROL

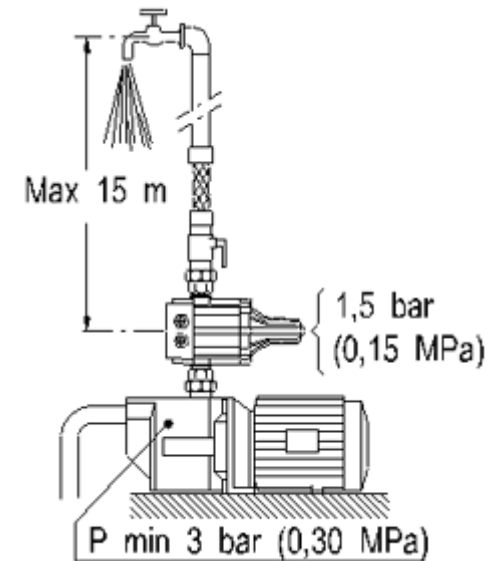



## 2,2 bar (0,22 MPa) Restart Pressure Calibration

The pressure of the pump must be a minimum of 3.5 bar (0.35 MPa), and a maximum of 10 bar (0.1 MPa).

The water column between the device and the highest tap must not exceed 22 metres.

## PRESSCONTROL

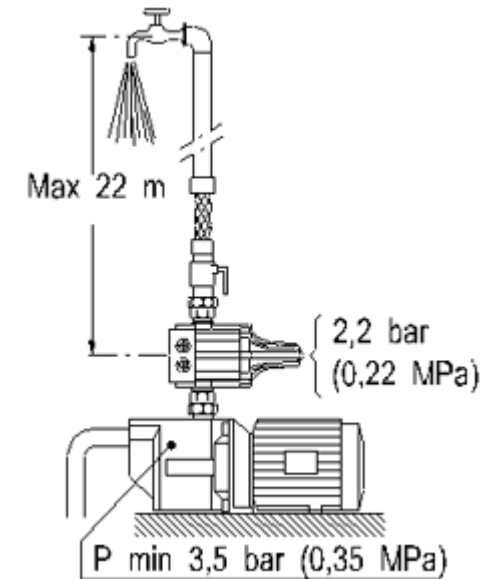



## Water Column

The pressure exerted by the water column that delivers to the device must be less than the restart pressure of the device otherwise the pump will turn on but fail to start.

To overcome this shortcoming either position the device higher up to create better conditions or use devices with higher restart pressure calibration values .

## PRESSCONTROL

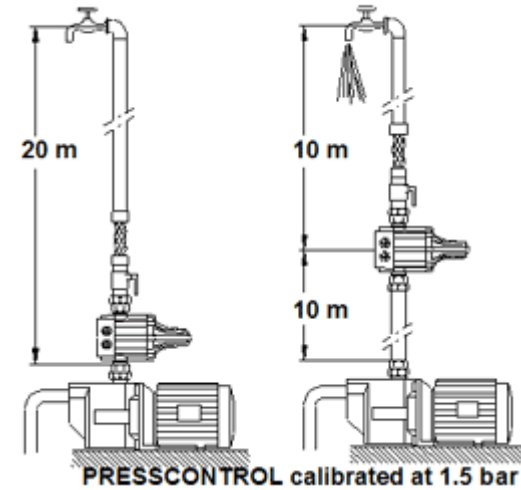





## Example: 20 metre Water Column

### PRESSCONTROL 1,5 bar Calibration

The pump has stopped, the system is under pressure and the tap is closed.

When the tap is opened the spring stretches but due to the effect of the antagonist pressure exerted by the water column, not sufficiently to allow the magnet inside the rod to interfere with the sensor. This prevents the pump from starting up.

## PRESSCONTROL

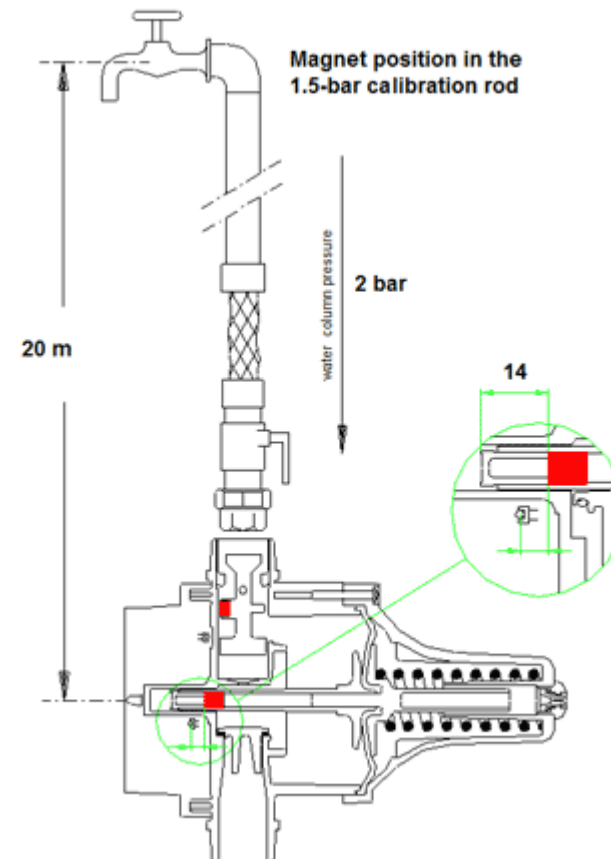



## PRESSCONTROL 2,2 bar Calibration

The fault can be overcome by installing a PRESSCONTROL with a calibration of 2.2 bar.

This model has the magnet inside the rod which is positioned further forwards and is therefore capable, under the same conditions, of interfering with the sensor.

This allows the pump to start up.

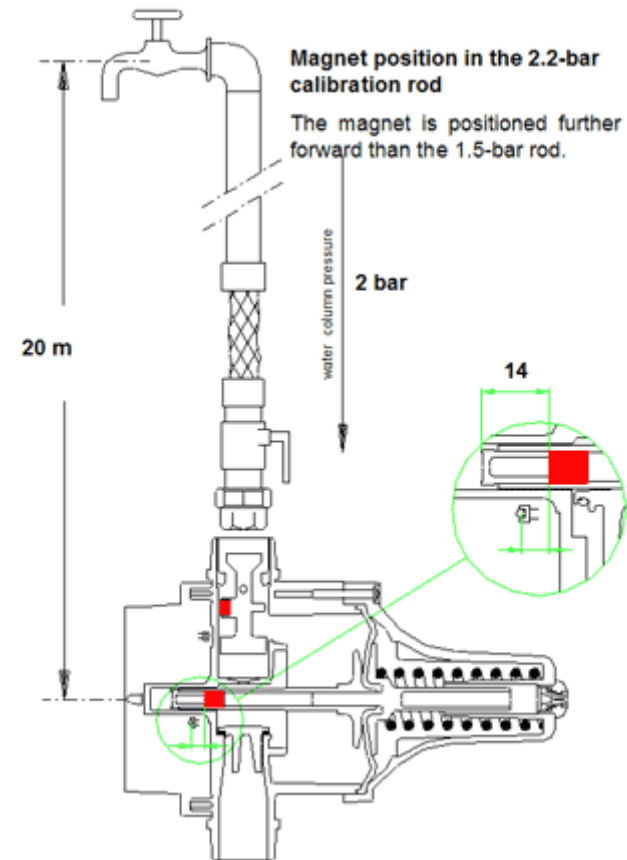



## Electrical Wiring

## PRESSCONTROL

It is recommended to always foresee the installation of a omnipolar switch with minimum opening of the contacts, equal to three millimetres, upstream from the device.

The monophase pumps (230 V) with motor powers of up to 1.5 kW (2 HP) can be connected directly to the device, whereas the same pumps with powers exceeding 1.5 kW (2 HP), and all the three-phase pumps (400 V) must be connected to the device by means of a remote control switch.

- Check the mains voltage and the nameplate data of the pump motor.
- Use H05 or H07 type cables with a section of 3x1 mm<sup>2</sup>.
- Ascertain that the device is connected to the earthing system.



## Electrical Wiring

Direct connection of the 230V monophasic motors with an input not exceeding 1.5 kW (2 HP).

*The use of a remote control switch is not necessary.*

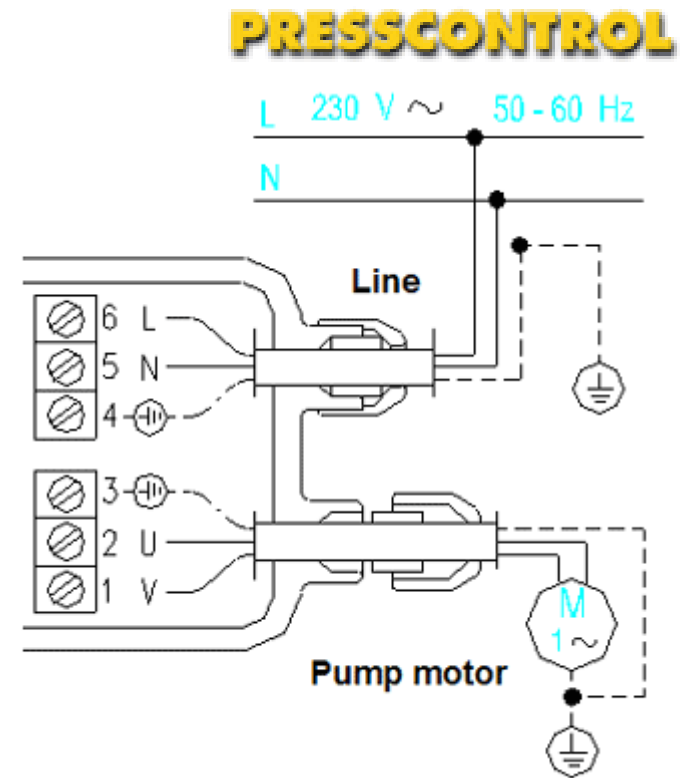



## Electrical Wiring

Connection by means of a remote control switch for 230V monophasic motors with an input exceeding 1.5 kW (2 HP).

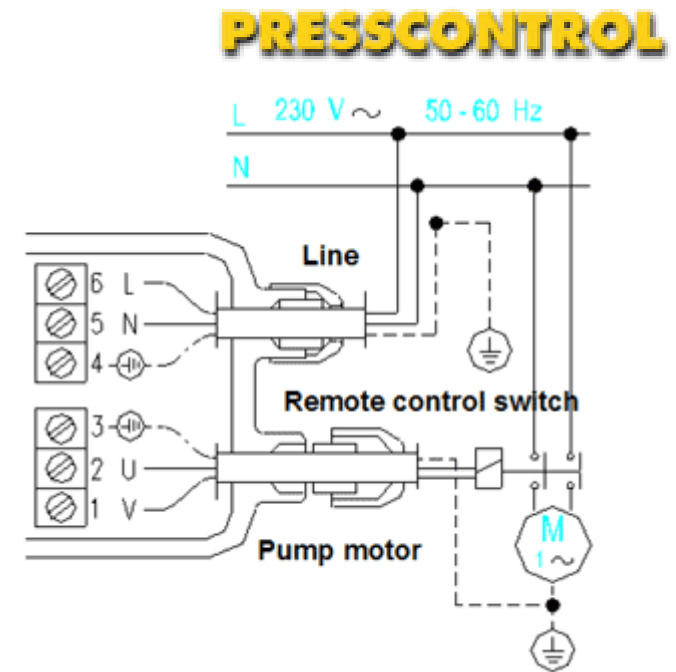



## Electrical Wiring

Connection by means of a remote control switch for 400V3N three-phase motors.

## PRESSCONTROL

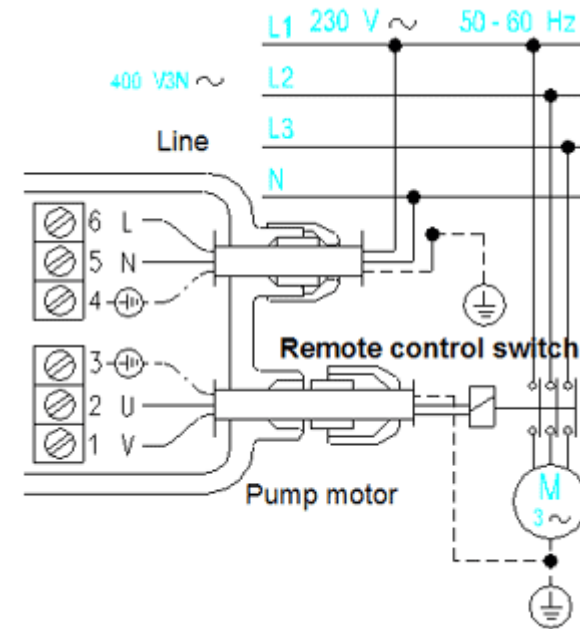



## Start Up

A panel is located on the front of the device that displays the operating phases of the system via the use of pilot lights. Green light: Power On (voltage), yellow light: Pump On , red light: Failure .

On connecting to the electrical mains the green pilot light turns on and the yellow one signals the start up of the pump.

The pump keeps operating for several seconds in order to allow the system to gain pressure.

Should this time be insufficient, the red pilot light will turn on. In this case keep the red Restart button pressed in and wait with a tap opened for the red light to turn off.

Once the tap has been closed, the device stops the pump and moves into standby with the green light turned on, ready to carry out all the following command and control operations in full autonomy.

## PRESSCONTROL

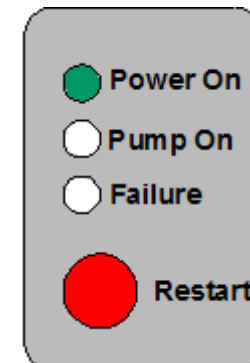



## Operation - System Operation

On opening a tap, the device starts the pump which remains in operation for the same time the tap remains open.

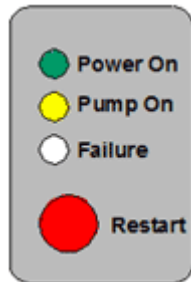

- Tap open
- Presence of flow
- Presence of pressure
- Pump running

## PRESSCONTROL

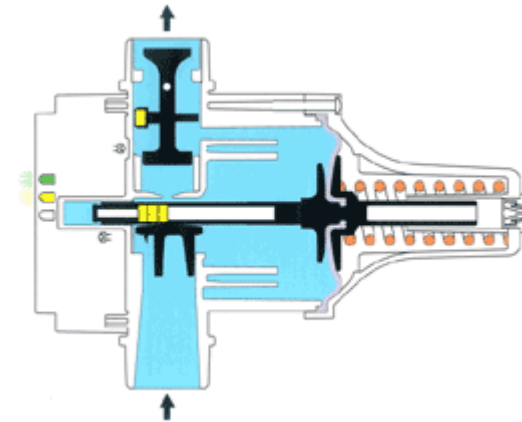





## Operation - System Under Pressure

On closing the tap, the device restores the maximum pressure to the system, stops the pump and returns to the standby position.

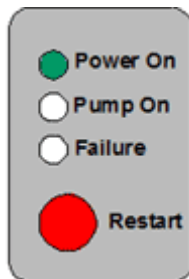

- System closed
- Absence of flow
- Presence of pressure
- Pump stopped

## PRESSCONTROL

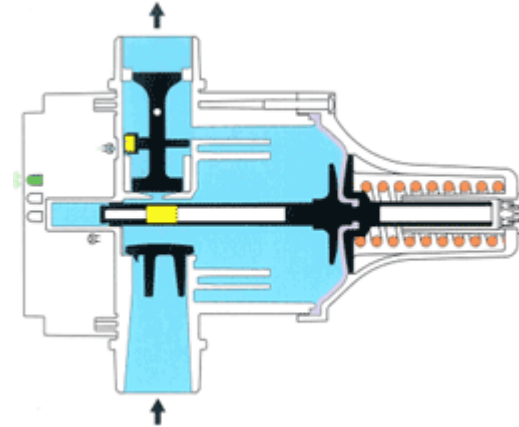



## Operation - System Stopped

In the event of a water shortage during aspiration, the device will recognise the fault, signal the same with the red pilot light Failure, and stop the pump to protect it from dry running.

After eliminating the causes of the stopping it is sufficient to press the red Restart button to restore normal operation.

In case of a temporary electricity cut-off the device will automatically start up again when the power returns.

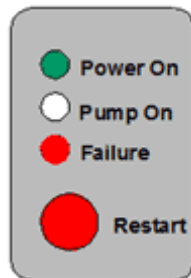

- Tap open
- Absence of flow
- Absence of pressure
- Pump stopped

## PRESSCONTROL

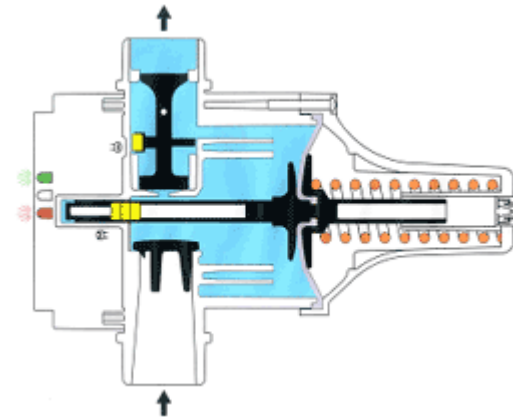



## Operating Faults

### Operating Faults

- The pump fails to turn on
- The pump turns on but fails to restart
- The pump functions intermittently
- The pump fails to stop
- The pump stops

## PRESSCONTROL

### Main Causes

- Check the electrical connections
- Excessive height of the water column
- Loss in system lower than minimum flow
- Loss in system higher than minimum flow
- Aspiration problems



## Checking the Operation

In the case of faults it is recommended to apply a ball valve to the output of the PRESSCONTROL.

This allows for testing the operation of the pump and the device and excluding the system by means of the valve for the purpose of troubleshooting and removing the cause of the malfunctioning.

## PRESSCONTROL

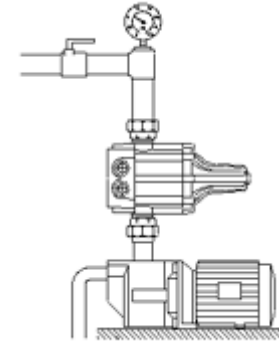



## Flow rate and Pressure Losses

## **PRESSCONTROL**

|              |                   |     |      |      |     |
|--------------|-------------------|-----|------|------|-----|
| Flow rate    | litres per minute | 50  | 75   | 100  | 125 |
| PRESSCONTROL | losses in bar     | 0,2 | 0,55 | 0,95 | /   |



## Two Pumps in Parallel

## PRESSCONTROL

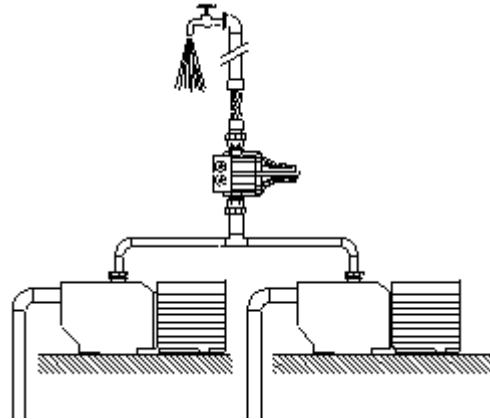

Both pumps always operate together:

- The flow rate is doubled.
- The head remains unvaried.

Connection of two pumps with a total input not exceeding 1.5 kW ( 2 HP ).

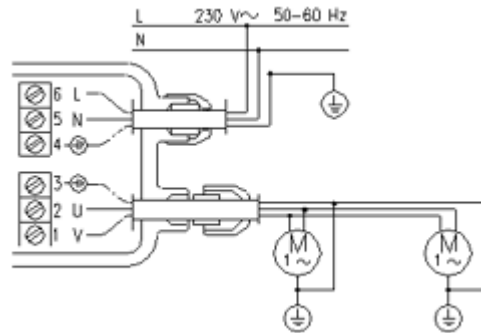

Connection of two pumps with a total input exceeding 1.5 kW ( 2 HP ).

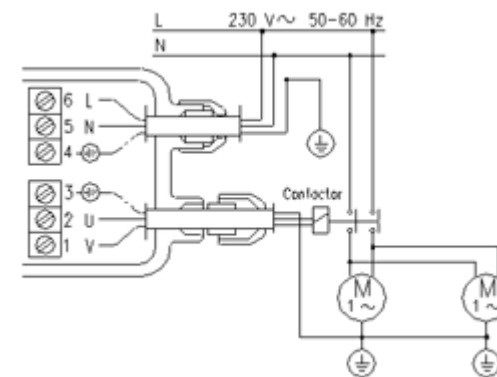



## Application of Reserve Pump

**PRESSCONTROL**

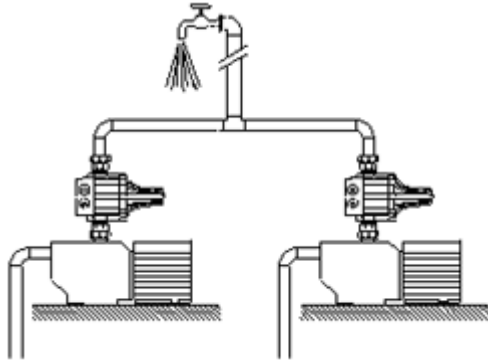

Two PRESSCONTROL devices with different restart pressure calibrations (T 1.2 bar and T 1.5 bar ).

In the case of a pump fault the water supply is still guaranteed.

For the electrical wiring please refer to the relative paragraph .



## Application in ByPass

**PRESSCONTROL**

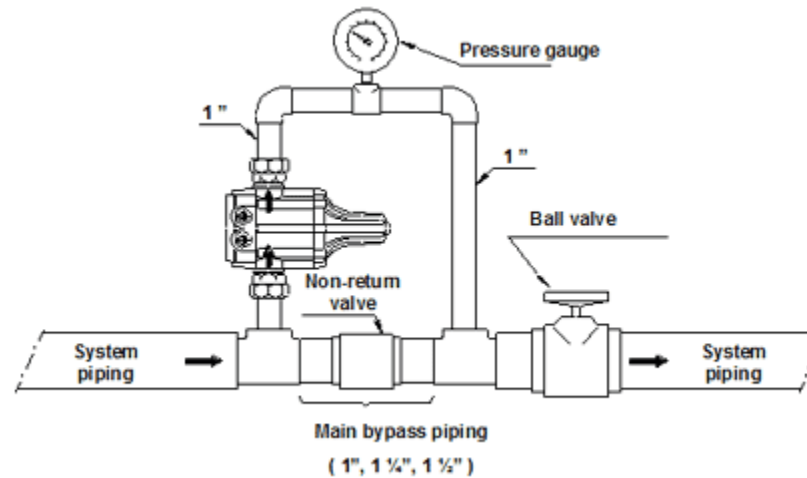

In the event of the pressure losses caused by the installation of the PRESSCONTROL taking the system flow rate down below the desired value, it is possible to install the PRESSCONTROL in bypass as indicated in the figure .

### Application in bypass

|                        |                   |      |      |      |      |
|------------------------|-------------------|------|------|------|------|
| Flow rate              | litres per minute | 100  | 150  | 200  | 250  |
| PRESSCONTROL x 1"      | losses in bar     | 0,25 | 0,6  | 1    | /    |
| PRESSCONTROL x 1 1/4"  | losses in bar     | 0,1  | 0,2  | 0,35 | 0,55 |
| PRESSCONTROL x 1 1/2 " | losses in bar     | /    | 0,15 | 0,3  | 0,45 |





## Application with Expansion Tank

**PRESSCONTROL**

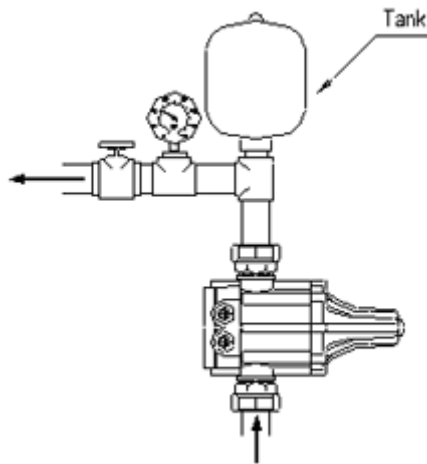

For minimal delivery demands, the application of a small expansion tank downstream from the PRESSCONTROL allows for reducing the pump start-ups.

(Example: a glass of water, ice-making machine, inverse osmosis systems or old systems with small losses).

It is recommended to preload the expansion tank at a slightly lower value than the restart pressure calibration value of the device.

(Example: PRESSCONTROL calibrated at 1.5 bar, tank preloaded at approximately 1.2 bar).