



Single channel centrifugal drainage pumps. Specifically designed for heavy duty applications they guarantee high capacity at medium head; ideal for civil and industrial applications. Available in mobile or permanent version with coupling feet.

Construction features

Painting	cataphoresis
Pump body	cast iron
	Impeller cast iron
Mechanical seal	double seal with oil barrier; silicon carbide on pump side, ceramic-graphite on motor side
Motor shaft	stainless steel AISI 304
Free passage	Ø max 50 mm
Max submergence	20 m
Liquid temperature	0 - 40 °C
Cable	H07 RN8F, 10 m
Bolts	A2 stainless steel
Foot support	galvanized iron
Gaskets	NBR rubber

TYPE	LOTS			
	TRUCK		CONTAINER	
	PALLET (cm)	N° pumps	PALLET (cm)	N° pumps
FM 160÷310	85×110×145	18	85×110×190	27
FM 410-560T	85×110×170	12	85×110×170	12
FM 1000T	100×120×190	12	100×120×190	12

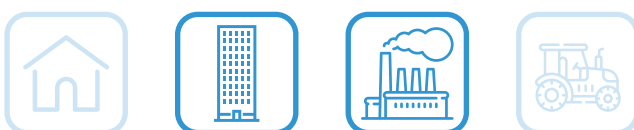

Motor

2 Poles induction motor	3~ 230V - 50Hz 3~ 400V - 50Hz 3~ 230/400V - 50Hz 3~ 400/690V - 50Hz
	1~ 230V - 50Hz required run capacitor (35µF for 1,5HP model, 50µF for 2HP model)
Insulation class	F
Protection degree	IPX8

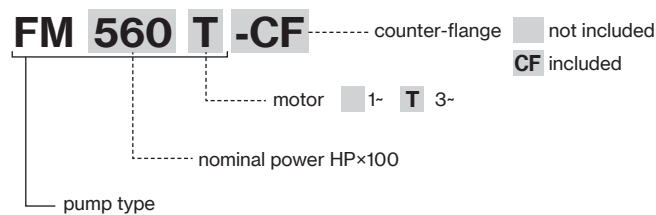

FM

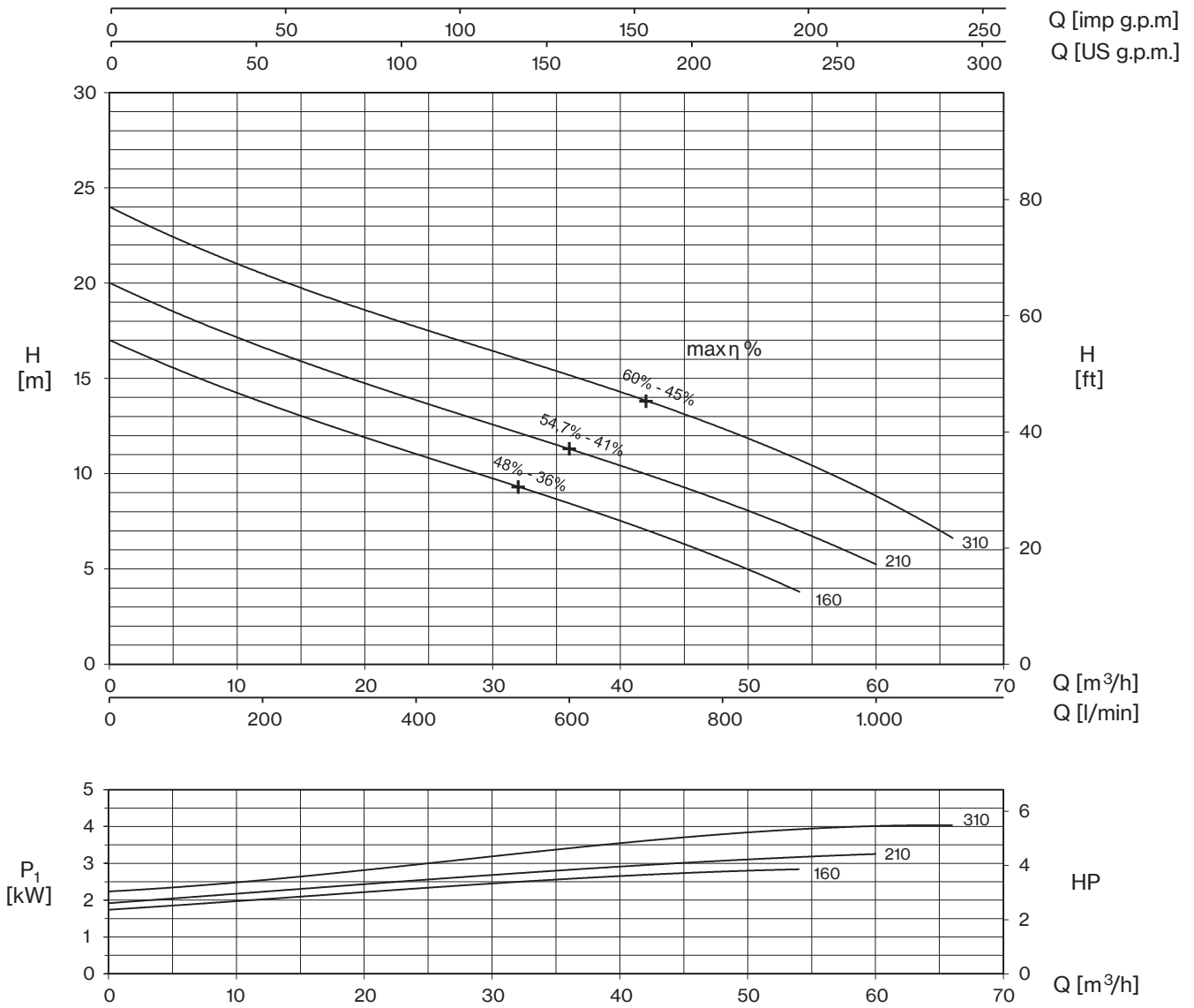

TYPE		AMPERE				
1~	3~	230V 50 Hz	3~ 230V 50 Hz (*)	3~ 400V 50 Hz	230/400 V 50 Hz λ/Δ (*)	400/690 V 50 Hz λ/Δ
FM 160	FM 160T	12,5	7,6	4,4	-	-
FM 210	FM 210T	15,0	9,5	5,5	-	-
-	FM 310T	-	12,0	6,9	-	-

+ max η %

max hydraulic efficiency and respective total efficiency

(*) no standard execution

TYPE		P2		P1 (kW)		Q (m³/h - l/min)												
1~	3~	HP	kW	1~	3~	0	6	12	18	24	30	36	42	48	54	60	66	
						0	100	200	300	400	500	600	700	800	900	1000	1100	
						H (m)												
FM 160	FM 160T	1,5	1,1	2,8	2,6	17,0	15,3	13,8	12,3	11,0	9,8	8,4	7,1	5,5	3,8			
FM 210	FM 210T	2	1,5	3,3	3,1	19,9	18,4	16,7	15,2	13,8	12,4	11,3	10,1	8,6	7,0	5,2		
-	FM 310T	3	2,2	-	4,1	23,9	22,2	20,6	19,1	17,8	16,3	15,0	13,8	12,3	10,9	9,1	6,4	

Q [imp g.p.m.]

Q [US g.p.m.]

Q [m³/h]

Q [l/min]

HP

Q [m³/h]

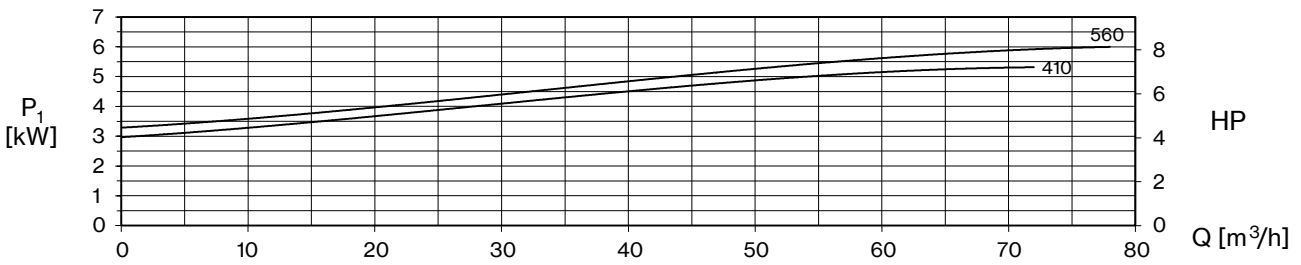
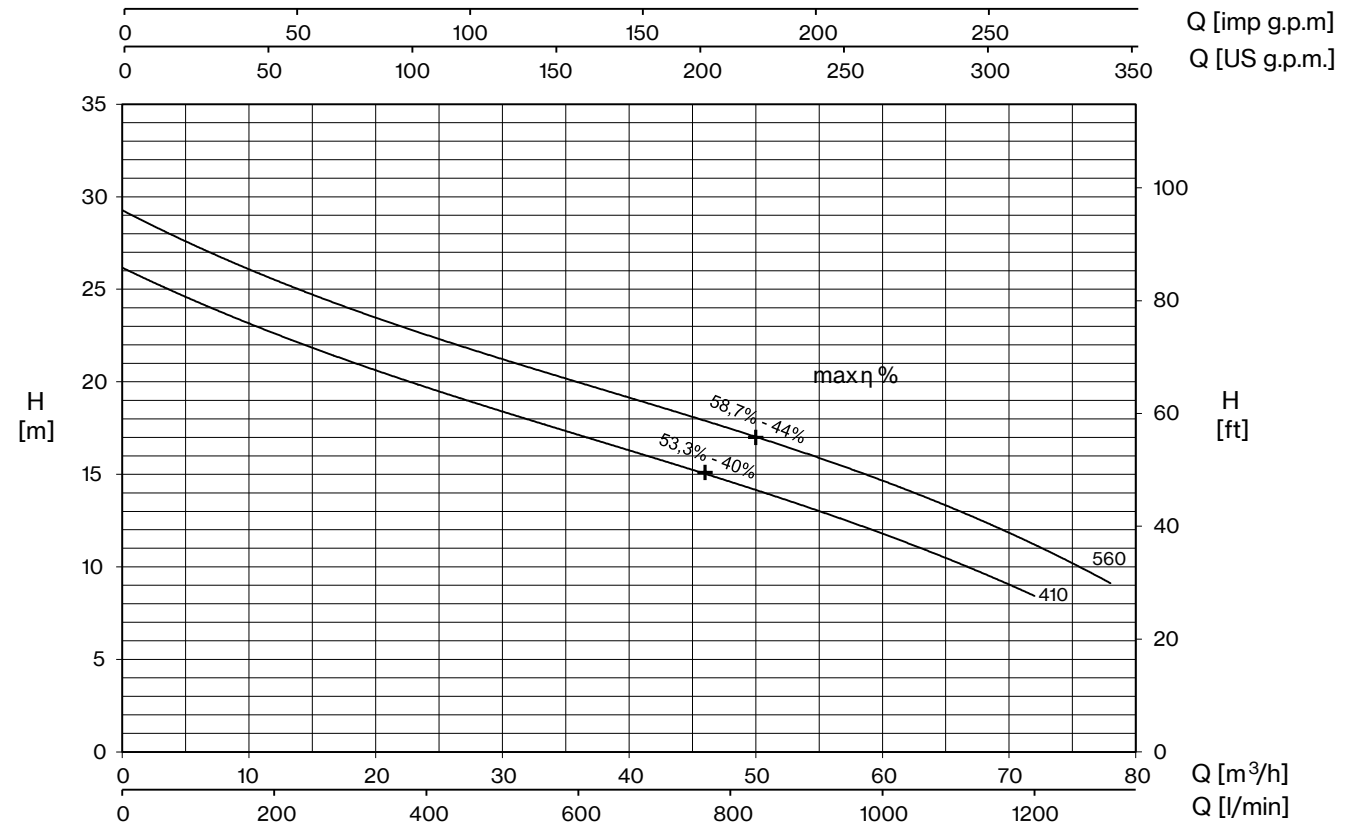

TYPE	AMPERE			
	3~ 230V 50 Hz (*)	3~ 400V 50 Hz	230/400 V 50 Hz λ / Δ (*)	400/690 V 50 Hz λ / Δ
FM 410T	15,4	8,9	-	-
FM 560T	17,6	10,2	-	-

+ max η %

max hydraulic efficiency and respective total efficiency

(*) no standard execution

TYPE	P2		P1 (kW)	Q (m ³ /h - l/min)										
				0	6	18	30	42	54	60	66	72	78	
	HP	kW	3~	0	100	300	500	700	900	1000	1100	1200	1300	
FM 410T	4	3	5,3	26,0	24,6	21,1	18,2	15,9	13,3	11,8	10,3	8,3		
FM 560T	5,5	4	6	29,1	27,5	24,1	21,1	18,6	16,1	14,7	13,1	11,4	8,9	

FM

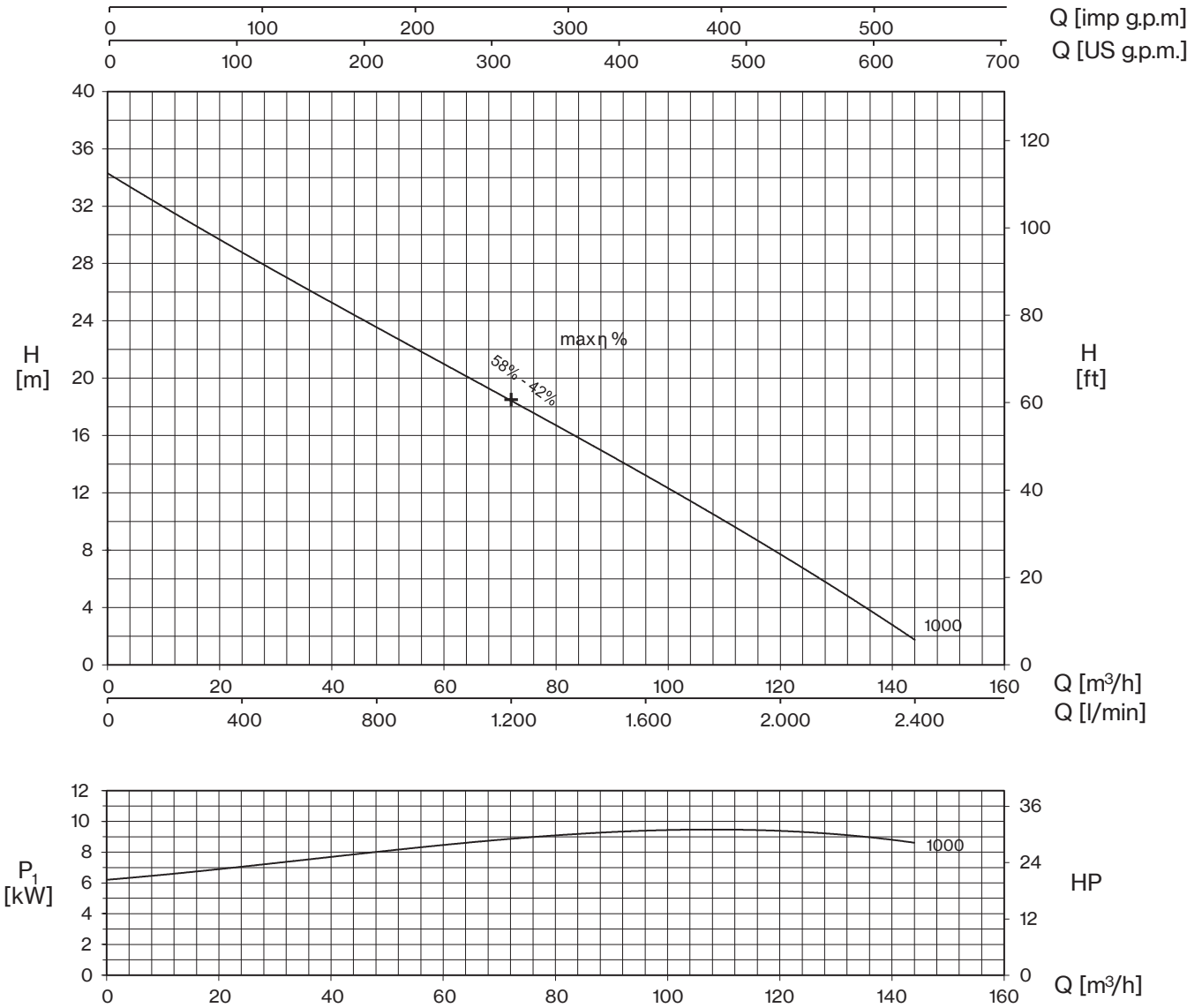

TYPE	AMPERE			
	3~ 230V 50 Hz (*)	3~ 400V 50 Hz	230/400 V 50 Hz λ / Δ (*)	400/690 V 50 Hz λ / Δ
FM 1000T	-	16,3	28,2	16,3

+ max η %

max hydraulic efficiency and respective total efficiency

(*) no standard execution

TYPE	P2		P1 (kW)	Q (m³/h - l/min)													
				0	12	24	36	48	60	72	84	96	108	120	132	144	
	HP	kW	3~	0	200	400	600	800	1000	1200	1400	1600	1800	2000	2200	2400	
FM 1000T	10	7,5	9,6	34,9	30,9	28,3	26,1	23,7	21,3	18,7	16,1	13,2	10,2	7,4	4,6	2,1	

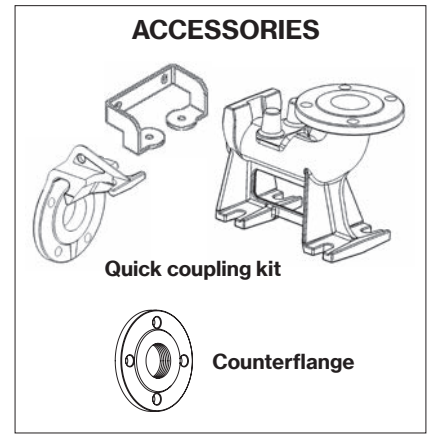
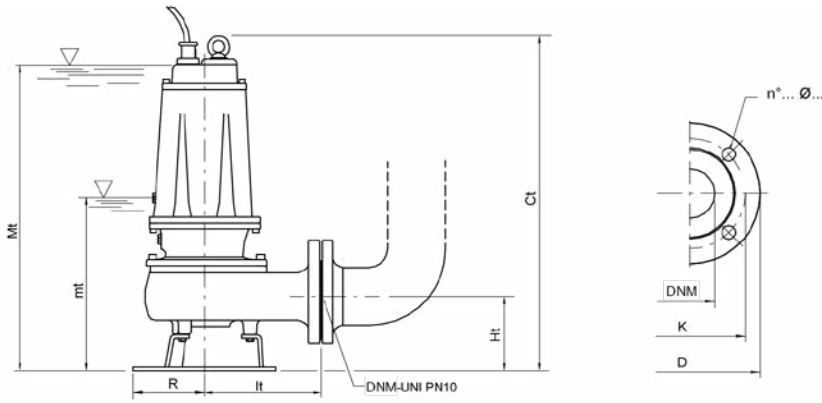

mt: minimum working level
Mt: minimum submersion level for continuous duty

TYPE	DIMENSIONS (mm)							Kg
	Ct	Ht	R	It	mt	Mt	DNM	
FM 160T	551	123	117	191	243	513	65	40
FM 160 - FM 210T	551	123	117	191	243	513	65	41,5
FM 210 - FM 310T	551	123	117	191	243	513	65	42,5
FM 410T	645	148	160	210	285	600	80	68
FM 560T	645	148	160	210	285	600	80	71,5
FM 1000T	725	178	180	232	358	670	80	94

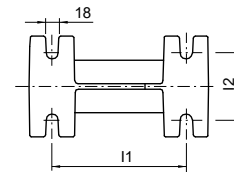
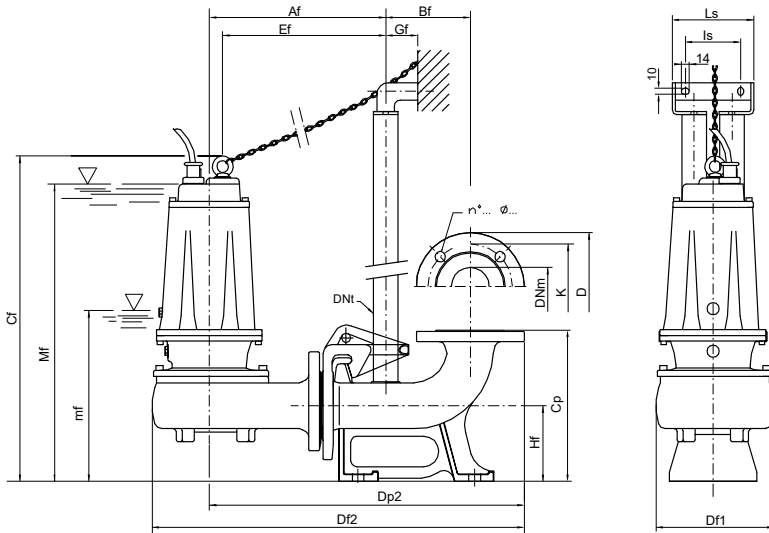

mf: minimum working level
Mf: minimum submersion level for continuous duty

Flange UNI PN 10 (mm)			
DNM	K	D	n°... Ø...
65	145	185	4... 18...
80	160	200	8... 18...

TYPE	DIMENSIONS (mm)																	
	Af	Bf	Cf	Cp	Df1	Df2	Dp2	Dnt	Ef	Gf	Hf	l1	l2	ls	Ls	mf	Mf	DNM
FM 160T/P	303	145	560	260	200	639	542	1" 1/4	280	55	130	200	100	95	140	251	521	65
FM 160/P - FM 210T/P	303	145	560	260	200	639	542	1" 1/4	280	55	130	200	100	95	140	251	521	65
FM 210/P - FM 310T/P	303	145	560	260	200	639	542	1" 1/4	280	55	130	200	100	95	140	251	521	65
FM 410T/P	350	165	690	340	220	722	615	2"	319	85	190	250	140	130	180	327	642	80
FM 560T/P	350	165	690	340	220	722	615	2"	319	85	190	250	140	130	180	327	642	80
FM 1000T/P	370	165	745	340	240	750	638	2"	350	85	190	250	140	130	180	380	690	80

TYPE	PROTECTION		1 PUMP CONTROL PANEL			2 PUMPS CONTROL PANEL		
	1- 230V	3- 400V	1- 230V	3- 400V	400/690 V	1- 230V	3- 400V	400/690 V
FM 160	PMC 15/35-15	PT 20-30-40/4.3-6.8	EQSM + 35µF	EQSMT 10		EQ2SM + 2x35µF	EQ2SMT 10	
FM 210	PMC 20/50-18	PT 20-30-40/4.3-6.8	EQSM + 50µF	EQSMT 10		EQ2SM + 2x50µF	EQ2SMT 10	
FM 310T		PT 40-50/5.7-9.1		EQSMT 10			EQ2SMT 10	
FM 400T		PT 55-75/8.6-13.5		EQSMT 10			EQ2SMT 10	
FM 560T		PT 55-75/8.6-13.5		EQSMT 10			EQ2SMT 10	
FM 1000T		PT 125-150/16-21		EQSMT 10	QST 10		EQ2SMT 10	Q2ST 10