



Two impeller centrifugal pumps for constructing pressurisation systems for civil and industrial plant; the two counter-posed impellers guarantee high head and flow rate.

Construction features

Pump body	cast iron
Motor bracket	cast iron
Impeller	Noryl® or brass (100÷900) brass (750÷1500)
Mechanical seal	ceramic-graphite-NBR
Motor shaft	stainless steel AISI 303 stainless steel AISI 416 (100)
Liquid temperature	Noryl® impeller: 0 - 50 °C brass impeller: 0 - 90 °C
Operating pressure	max 6 bar (100) max 11 bar (160÷1500)

Motor

	3- 230/400V - 50Hz P ≤ 4kW
2 Poles induction motor	1- 230V - 50Hz (with thermal protection up to MEC 80)
Insulation class	F
Protection degree	IPX4 IPX5 (KB750÷1500)

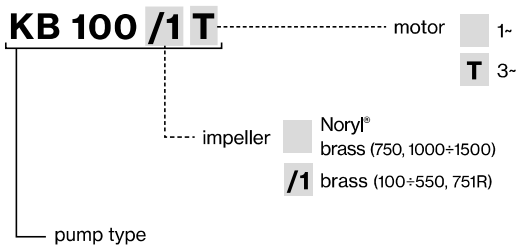

TYPE	LOTS			
	TRUCK		CONTAINER	
	PALLET (cm)	N° pumps	PALLET (cm)	N° pumps
KB 100	90×110×145	65	90×110×195	91
KB 160-KB 310T	85×110×130	40	85×110×190	60
KB 310	85×110×150	24	85×110×180	30
KB 400÷900	80×120×150	24	80×120×180	30
KB 750÷1500T	100×120×140	18	100×120×185	24

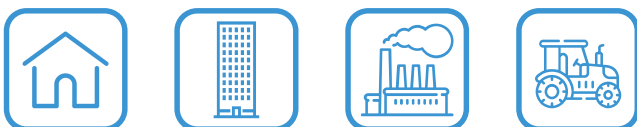

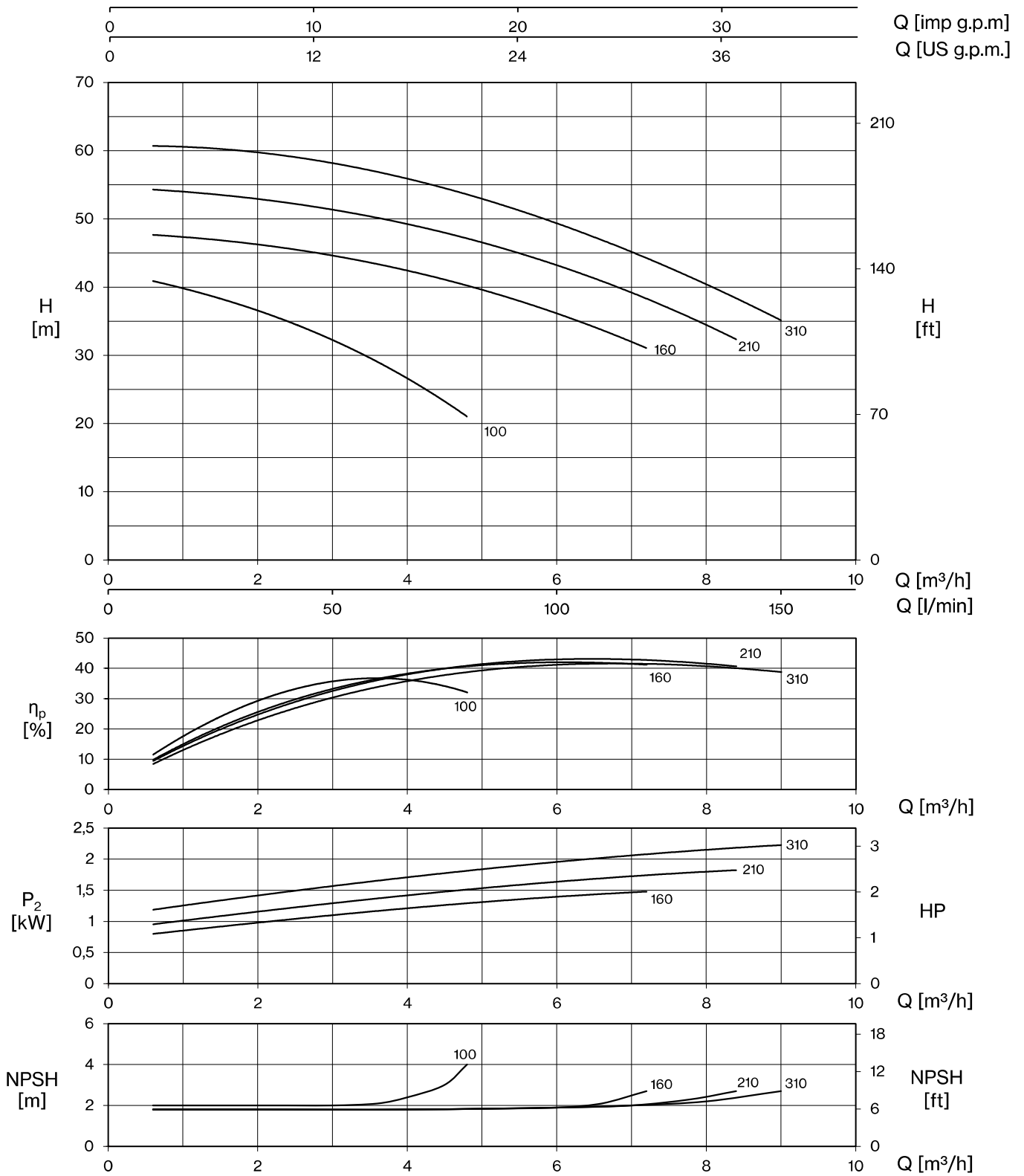

TYPE		P2		P1 (kW)		AMPERE		Q (m³/h - l/min)															
1-	3-					1-	3-	0	0,6	1,2	1,8	2,4	3,6	4,8	6	7,2	8,4	9					
		HP	kW	1-	3-	1- 230V 50 Hz	3- 400V 50 Hz	0	10	20	30	40	60	80	100	120	140	150					
		H (m)																					
KB 100	KB 100T	1	0,74	1,17	1,15	5,4	2,4	42,0	40,8	39,4	37,4	34,7	29,2	21,0									
KB 160	KB 160T	2	1,5	1,9	1,8	8,5	3,7	48,3	47,7	47,1	46,5	45,7	43,5	40,1	36,2	31,1							
KB 210	KB 210T	2,5	1,85	2,3	2,2	10,4	4,4	54,9	54,4	53,8	53,0	52,3	50,5	47,1	43,1	38,3	32,4						
KB 310	KB 310T	3	2,2	2,8	2,6	13,0	5,2	61,4	60,9	60,3	59,8	59,2	57,1	53,6	49,3	44,2	38,3	35,2					

KB

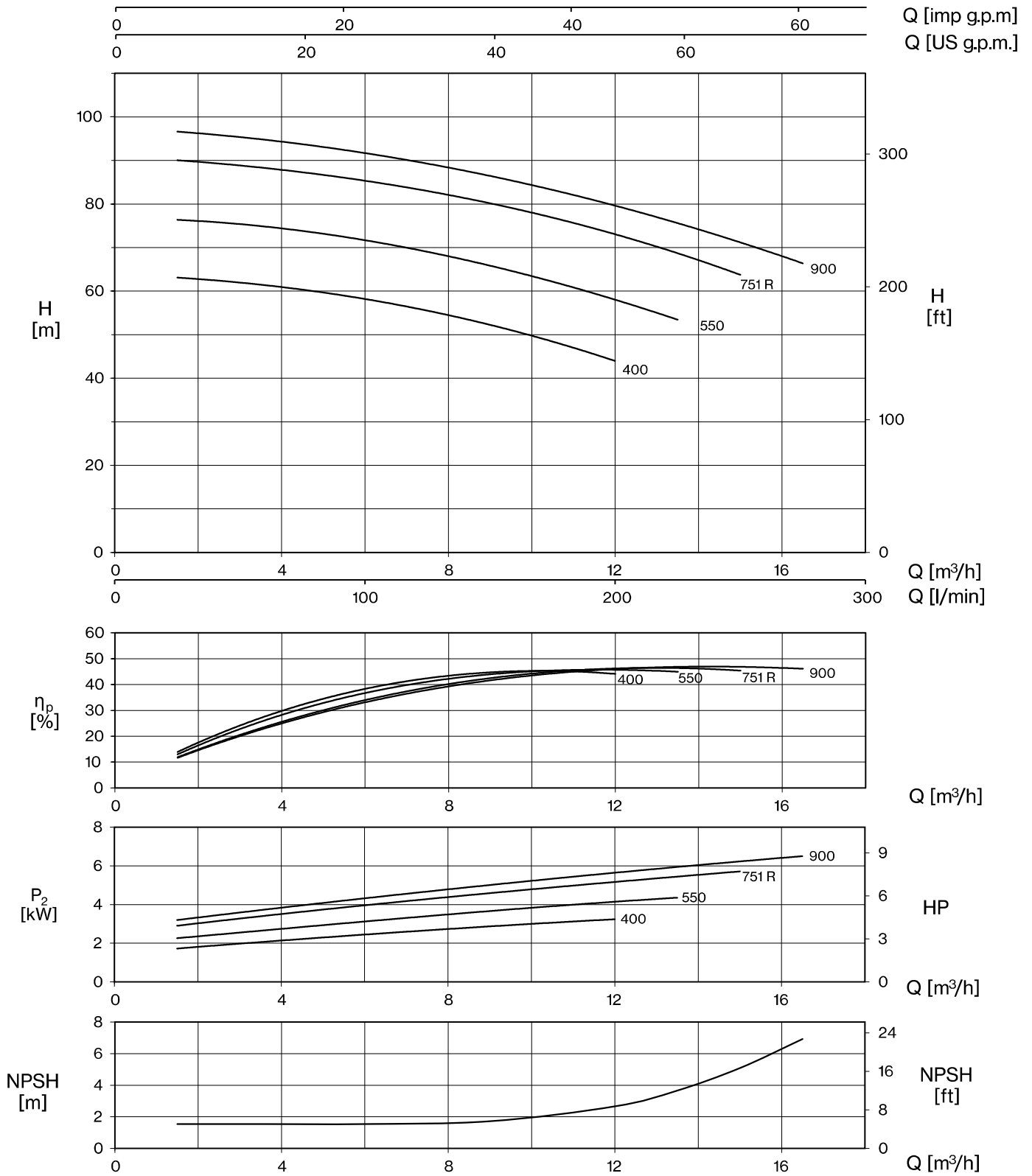

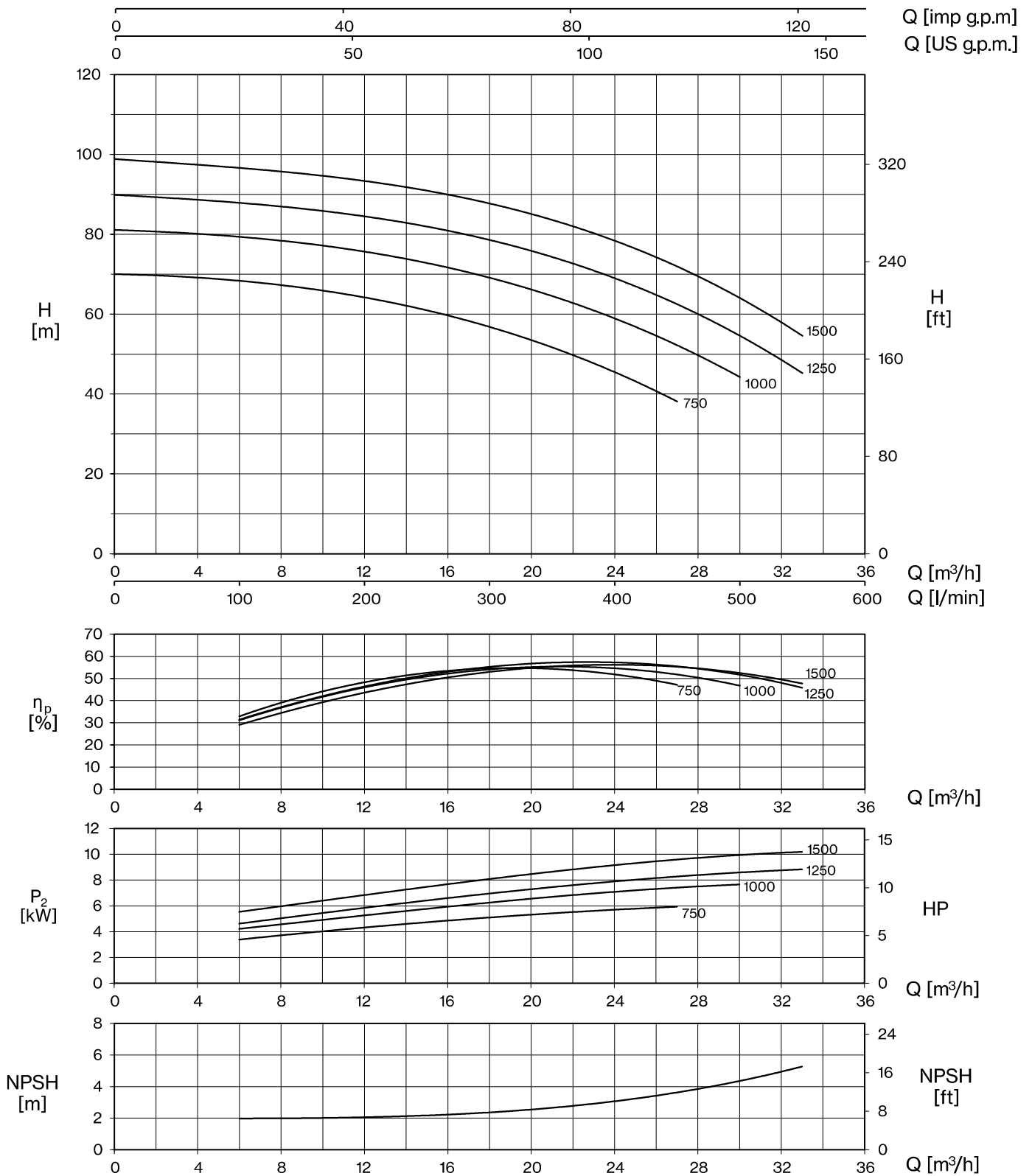

TYPE		P2		P1 (kW)		AMPERE		Q (m³/h - l/min)												
1~	3~	HP	kW	1~	3~	1~ 230V 50 Hz	3~ 400V 50 Hz	0	1,5	3,0	4,5	6,0	7,5	9,0	10,5	12	13,5	15,0	16,5	
								0	25	50	75	100	125	150	175	200	225	250	275	
								H (m)												
KB 400	KB 400T	4	3,0	3,7	3,8	16,4	6,7	63,6	63,1	62,0	60,3	58,2	55,5	52,3	48,4	43,9				
KB 550	KB 550T	5,5	4,0	5,2	5,0	23,3	9,1	76,9	76,4	75,4	73,8	71,7	69,0	65,9	62,1	58,0	53,4			
-	KB 751RT	7,5	5,5	-	6,5	-	11,5	90,7	90,0	88,9	87,3	85,3	82,9	80,1	76,8	73,1	68,8	63,7		
-	KB 900T	10	7,5	-	7,3	-	13,3	97,5	96,6	95,4	93,7	91,7	89,2	86,5	83,3	79,8	75,2	71,2	66,4	

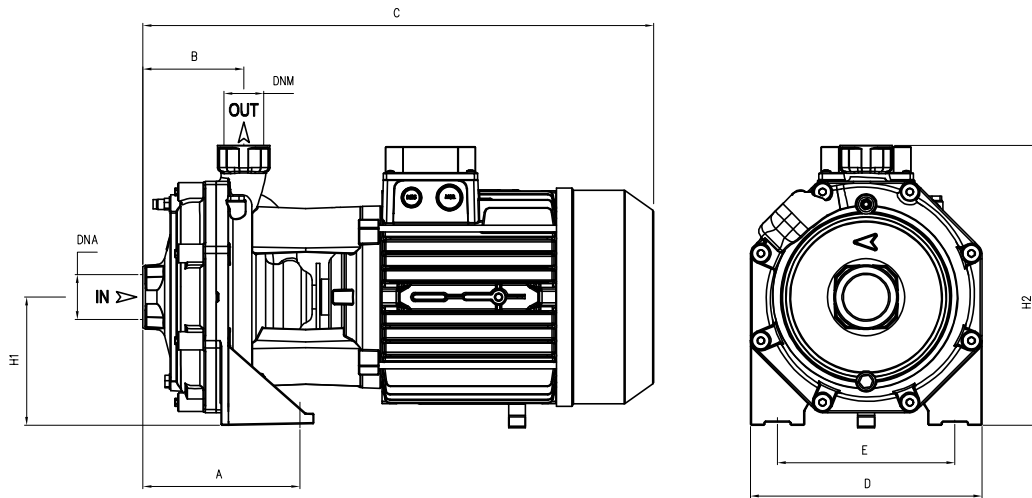

TYPE	P2		P1 (kW)	AMPERE	Q (m³/h - l/min)								
					0	6	12	18	24	27	30	33	
	HP	kW	3-	3- 400V 50 Hz	0	100	200	300	400	450	500	550	
KB 750T	7,5	5,5	6,7	11,1	70,0	68,5	63,9	57,1	45,3	38,2			
KB 1000T	10	7,5	8,5	13,9	80,7	80,4	75,0	68,5	59,7	52,6	43,7		
KB 1250T	12,5	9,2	9,8	16,3	89,5	88,8	84,1	77,7	69,7	63,0	54,2	45,1	
KB 1500T	15	11,0	11,2	18,6	98,3	97,8	93,5	85,7	78,9	73,3	64,0	54,0	



TYPE		DIMENSIONS (mm)													
~1	~3	A	B	C	D	E	H1	H2	DNA	DNM	I	L	M	~1	~3
KB 100	KB 100T	122	72	328	180	140	98	228	1" G	1" G	350	195	265	15,5	15
KB 160	KB 160T	115	82	408	210	170	110	265			433	220	287	25,5	26,5
KB 210	KB 210T	115	82	408	210	170	110	265	1" ¼ G		433	220	287	26	27
KB 310	-	115	82	477	210	170	110	265			520	235	320	35,5	-
-	KB 310T	115	82	408	210	170	110	265			433	220	287	-	27,5
KB 400	KB 400T	145	95,5	498	266	212	135	305	1" ½ G	1" ¼ G	553	274	318	48	44
KB 550	KB 550T	145	95,5	498	266	212	135	305			553	274	318	56,5	48
-	KB 751RT	145	95,5	532	266	212	135	305			553	274	318	-	56
-	KB 900T	145	95,5	532	266	212	135	305				553	274	318	-
-	KB 750T	190	120	605	275	210	150	330	2" G	1" ¼ G	675	390	300	-	78
-	KB 1000T	190	120	605	275	210	150	330			675	390	300	-	84
-	KB 1250T	190	120	645	275	210	150	330			675	390	300	-	91,5
-	KB 1500T	190	120	645	275	210	150	330			675	390	300	-	95,5